

ST MCU

Boot Modes Selection

BOOT mode selection pin		Boot mode
BOOT1	BOOT0	
X	0	Main Flash memory
0	1	System memory
1	1	Embedded SRAM

The BOOT1 value is the opposite of the BOOT0 option bit.

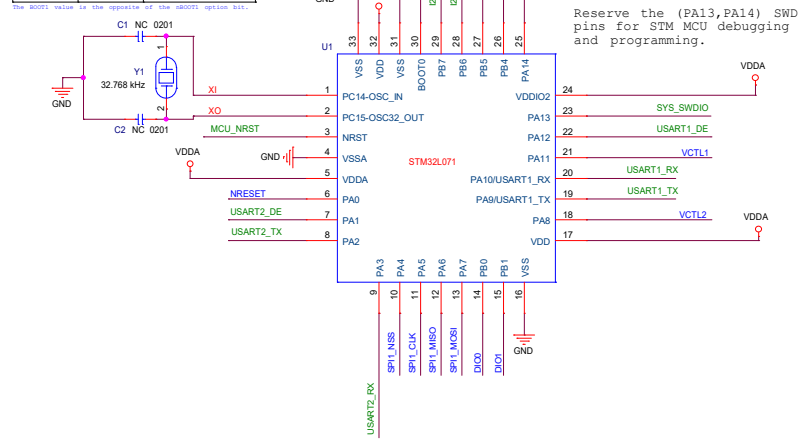
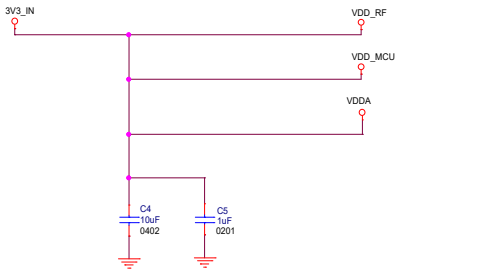

Reserve the (PA13, PA14) SWD pins for STM MCU debugging and programming.

Module Stamp Pinout

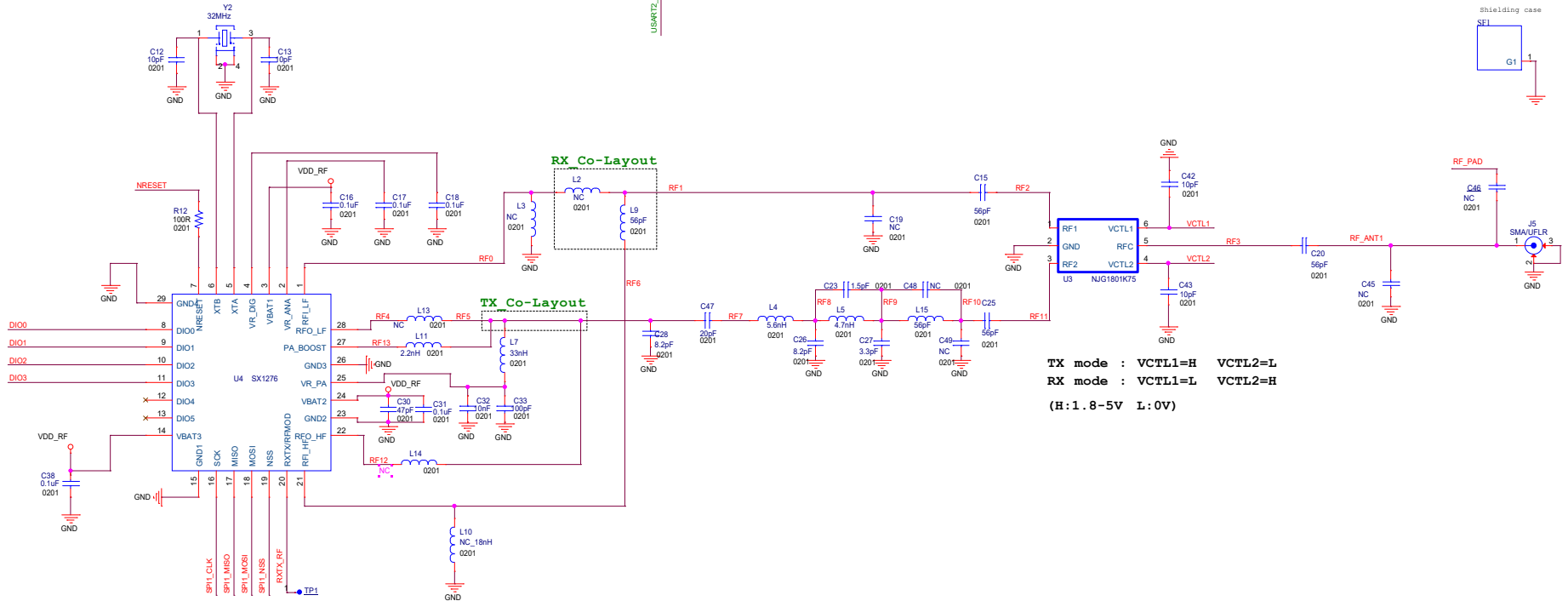
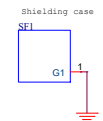
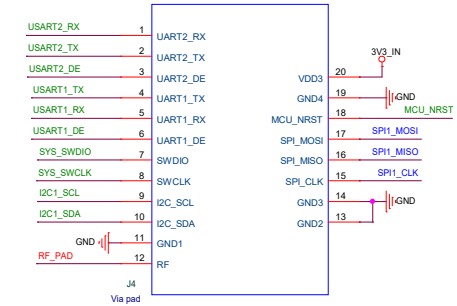

TX mode : VCTL1=H VCTL2=L
RX mode : VCTL1=L VCTL2=H
(H: 1.8-5V L: 0V)

Title		
Size	Document Number	Rev
C		V00
Date:	Tuesday, June 19, 2018	Sheet 1 of 1